

POWER RELAY

1 POLE - 8A Polarized Latching Type JSL Series

■ FEATURES

- Small footprint
 - Width: 10mm
 - Height: 12.5mm
- High isolation
 - Insulation distance: 8 mm (between coil and contacts)
 - Dielectric strength: 5,000 VAC (between coil and contacts)
 - Surge strength: 10,000 V (between coil and contacts)
- Plastic materials
 - UL 94 flame class V-0
- Plastic sealed type
- Cadmium free relay
- Lead-free relay
- RoHS compliant.

Please see page 5 for more information



■ PARTNUMBER INFORMATION

[Example] JS L D 12 M N - K
 (a) (b) (c) (d) (e) (f) (g)

(a)	Relay type	JS	: JS Series
(b)	Operating function	L	: Latching type
(c)	Coil type	Nil D	: 1 coil : 2 coils
(d)	Coil rated voltage	12	: 3.....24 VDC Coil rating table at page 3
(e)	Contact configuration	Nil M	: 1 form C : 1 form A
(f)	Contact material	N	: AgSnO ₂ , Au plated
(g)	Sealed type	K	: Wash tight

JSL SERIES

■ SPECIFICATION

Item			JSL (1 coil)	JSL (2 coils)
Contact Data	Configuration		1 form A, 1 form C	
	Construction		Single	
	Material		AgSnO ₂	
	Resistance (initial)		≤ 100 mΩ at 6VDC, 1A	
	Contact rating		8A, 250VAC / 24VDC	
	Max. carrying current		10A	
	Max. switching voltage		400VAC / 150VDC	
	Max. switching power		2,000VA	
	Max. switching current		10A	
	Min. switching load *		100 mA, 5 VDC	
Life	Mechanical		5 x 10 ⁶ operations minimum	
	Electrical		50 x 10 ³ operations minimum	
Coil Data	Rated power (at 20 °C)		220mW	480mW
	Operating temperature range		-40 °C to +70 °C (no frost)	
Timing Data	Set / reset (at nominal coil voltage)		≤ 10ms (no bounce included)	
	Exitation time		≥ 20ms	
Insulation	Resistance (initial)		≥ 1,000MΩ at 500VDC	
	Dielectric strength	Open contacts	1,000VAC (50/60Hz) 1min	
		Contacts to coil	5,000VAC (50/60Hz) 1min	
	Surge strength	Coil to contacts	10,000V / 1.2 x 50μs standard wave	
	Clearance		8 mm	
	Creepage		8 mm	
Other	Vibration resistance	Misoperation>1us	10 to 55Hz double amplitude 2 mm	
		Endurance	10 to 55Hz double amplitude 3 mm	
	Shock	Misoperation>1us	Min. 200m/s ² (11 ± 1ms)	
		Endurance	Min. 1,000m/s ² (6 ± 1ms)	
	Weight		Approximately 8 g	

* Minimum switching loads mentioned above are reference values. Please perform the confirmation test with actual load before production since reference values may vary according to switching frequencies, environmental conditions and expected reliability levels.

■ COIL RATING

Coil Code	1 coil			2 coils		
	Operating range		Coil Resistance +/- 10% (Ohm)	Operating range		Coil Resistance +/- 10% (Ohm)
	Min. VDC	Max. VDC		Min. VDC	Max. VDC	
3	2.4	5.4	41	2.4	5.4	19
5	4	9	114	4	9	53
6	4.8	10.6	164	4.8	10.6	75
9	7.2	15.9	368	7.2	15.9	169
12	9.6	21.2	655	9.6	21.2	300
24	19.2	42.2	2,304	19.2	42.2	1,200

Note: All values in the table are measured at 20°C and zero contact current.

* Specified values are measured with pulse wave voltage.

■ COIL POLARITY

Version	1 coil		2 coils		
Coil terminal division	A	C	A	B	C
Set	+	-	+	-	
Reset	-	+		-	+

■ DIMENSIONS

● Dimensions

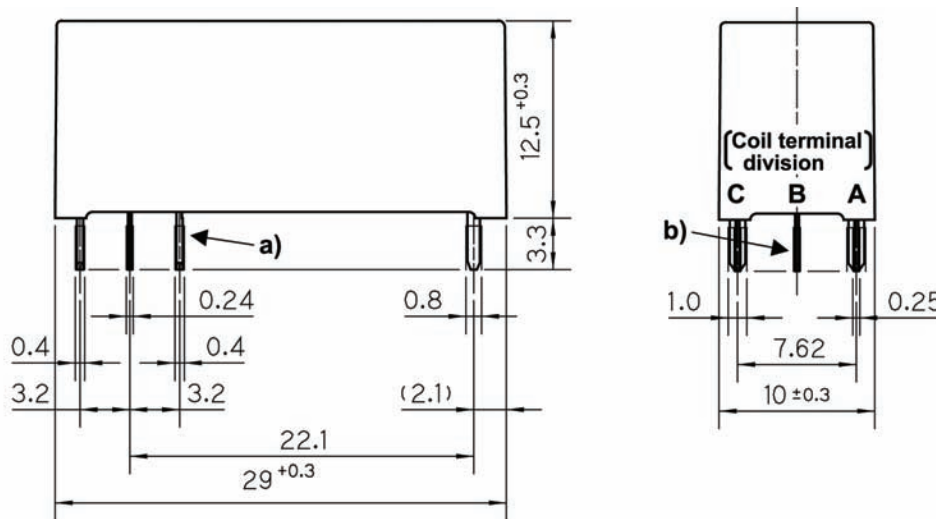

● Schematics (BOTTOM VIEW)

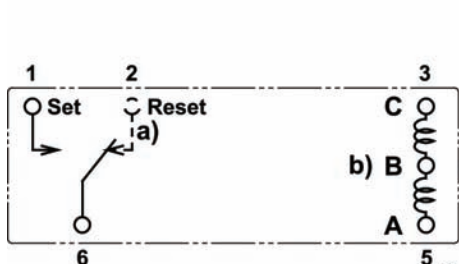

● PC board mounting hole layout (BOTTOM VIEW)

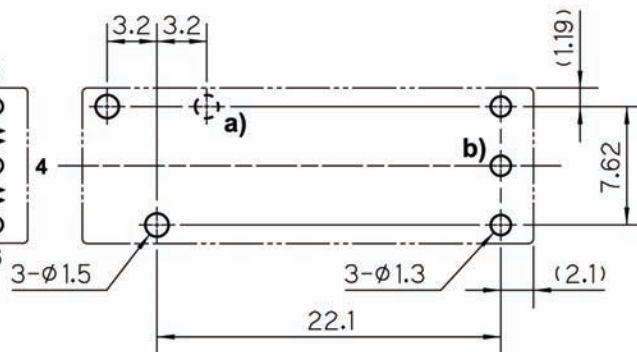

a) for 1 form C version only
b) for 2 coils version only

Unit: mm

RoHS Compliance and Lead Free Information

1. General Information

- All signal and power relays produced by Fujitsu Components are compliant with RoHS directive 2002/95EC including amendments.
- Cadmium as used in electrical contacts is exempted from the RoHS directives on October 21st, 2005. (Amendment to Directive 2002/95/EC)
- All of our signal and power relays are lead-free. Please refer to Lead-Free Status Info for older date codes at: <http://www.fujitsu.com/us/downloads/MICRO/fcai/relays/lead-free-letter.pdf>
- Lead free solder plating on relay terminals is Sn-3.0Ag-0.5Cu, unless otherwise specified. This material has been verified to be compatible with PbSn assembly process.

2. Recommended Lead Free Solder Profile

- Recommended solder Sn-3.0Ag-0.5Cu.

Flow Solder condition:

Pre-heating: maximum 120°C
Soldering: dip within 5 sec. at
260°C solder bath

Solder by Soldering Iron:

Soldering Iron
Temperature: maximum 360°C
Duration: maximum 3 sec.

We highly recommend that you confirm your actual solder conditions

3. Moisture Sensitivity

- Moisture Sensitivity Level standard is not applicable to electromechanical relays, unless otherwise indicated.

4. Tin Whiskers

- Dipped SnAgCu solder is known as presenting a low risk to tin whisker development. No considerable length whisker was found by our in house test.

Fujitsu Components International Headquarter Offices

Japan

Fujitsu Component Limited
Gotanda-Chuo Building
3-5, Higashigotanda 2-chome, Shinagawa-ku
Tokyo 141, Japan
Tel: (81-3) 5449-7010
Fax: (81-3) 5449-2626
Email: promothq@ft.ed.fujitsu.com
Web: www.fcl.fujitsu.com

North and South America

Fujitsu Components America, Inc.
250 E. Caribbean Drive
Sunnyvale, CA 94089 U.S.A.
Tel: (1-408) 745-4900
Fax: (1-408) 745-4970
Email: components@us.fujitsu.com
Web: <http://us.fujitsu.com/components>

Europe

Fujitsu Components Europe B.V.
Diamantlaan 25
2132 WV Hoofddorp
Netherlands
Tel: (31-23) 5560910
Fax: (31-23) 5560950
Email: info@fceu.fujitsu.com
Web: emea.fujitsu.com/components/

Asia Pacific

Fujitsu Components Asia Ltd.
102E Pasir Panjang Road
#01-01 Citilink Warehouse Complex
Singapore 118529
Tel: (65) 6375-8560
Fax: (65) 6273-3021
Email: fcal@fcal.fujitsu.com
Web: <http://www.fujitsu.com/sg/services/micro/components/>

©2009 Fujitsu Components Europe B.V. All rights reserved. All trademarks or registered trademarks are the property of their respective owners.

The contents, data and information in this datasheet are provided by Fujitsu Component Ltd. as a service only to its user and only for general information purposes.

The use of the contents, data and information provided in this datasheet is at the users' own risk.

Fujitsu has assembled this datasheet with care and will endeavor to keep the contents, data and information correct, accurate, comprehensive, complete and up to date.

Fujitsu Components Europe B.V. and affiliated companies do however not accept any responsibility or liability on their behalf, nor on behalf of its employees, for any loss or damage, direct, indirect or consequential, with respect to this datasheet, its contents, data, and information and related graphics and the correctness, reliability, accuracy, comprehensiveness, usefulness, availability and completeness thereof.

Nor do Fujitsu Components Europe B.V. and affiliated companies accept on their behalf, nor on behalf of its employees, any responsibility or liability for any representation or warrant of any kind, express or implied, including warranties of any kind for merchantability or fitness for particular use, with respect to these datasheets, its contents, data, information and related graphics and the correctness, reliability, accuracy, comprehensiveness, usefulness, availability and completeness thereof. Rev. October 30, 2009